



# Product Manual



# Catalog

PLS read the following instructions carefully to make sure this machine will work under good condition and avoid the unnecessary loss.

Catalog .....	1
Warm Instructions.....	2-3
Functions And Features .....	4
Industrial Dehumidifier Operation Tips .....	5-6
N2 Cabinets Operation Tips .....	7-8
Cabinets Proceeding (Double Flow Meter ) .....	9-10
Auto-nitrogen and Humidity Control Cabinets Operation Instructions .....	11-12
N2 Generator Cabinets Operation Tips .....	13-14
FAQ & Processing .....	15-17

# Warm Prompt

## Important Tips Before Using

1. For first user, PLS read these instructions carefully. If you don't follow these rules and may cause problems then we won't bear any responsibilities PLS understand.
2. Do not place this machine in air flow (such as an air-conditioner, exhaust fan, electric fan, doorway, etc) Heavy smog and steam which will affect the results.
3. PLS place this machine without direct sunlight.
4. The distance between the machine and the wall should be around 20cm for good condition.
5. First time to be used or reused after a long time, PLS run this machine ahead of time at least 12 hours without any containers to make sure a good condition.
6. PLS put items even weights onto these shelves without overloading, otherwise the shelves will tipping and may cause loss then we won't bear any responsibilities PLS understand.

## Tips on Placing This Machine

1. During working time PLS keep a certain distance from the wall and do not cover the exhaust vent and leave some space for ventilation to make sure the machine will work well.
2. Storage items the RH will up due to the humidity themselves, It will take 1-2 days to dry, if they are packaged by wrapping papers or wood it will take more time to dry. Shorten the time opened the door for the RH in air will affect the results.
3. PLS sealed up the stocks (such as foods and chemicals) otherwise it will limit the effect and mixture odor.

## Basic Knowledge About Dehumidification

1. Make sure the values you set is lower than the environmental humidity otherwise this machine won't work. Perfect environment temperature at 30°C, RH value at 60%RH
2. If you want to increase the inner humidity values then you can open the door for a while then close the door.
3. The High precision humidity sensor with the accuracy less than  $\pm 3\%$ RH and annual measurement error  $\pm 3\%$ RH; produced by HONEYWELL in America (the world biggest and leading sensors manufacturer).

If the RH value indicated in the machine is different from actual value, they are adjustable however not be suggested as we have done before.

Ways to test the machine: First whether they are produced by a formal company. Second whether passed the test of National Testing Agency and adjustment once per six months to make sure the accuracy.

4. This machine can work in mute condition in 20%RH values without any items. The 3%RH and 1%RH values are ideal condition. We can meet the RH values below 15%
5. During working the outer shutter will open and the surface of units will warmer no need to worry about it.

## LED Panel Functions



## Different state of dehumidification

- ◆ Run on and OUT out, the dehumidifier core output humidity.
- ◆ Both OUT & RUN are on the dehumidifier core is working well.
- ◆ OUT on and RUN out, inner RH value lower than set RH value, dehumidifier core input humidity until to the set RH value then the OUT will out.
- ◆ Both OUT and RUN are out the inner RH value achieve the set RH value.

No more water drop during operating, if there are any problems with this display PLS contact with us, we can help you to fix it from these indicator lights.

Remarks: run and out indicated in the display of Nitrogen Control Cabinets or N2 Generator Cabinets have no practical significance, just care the RH values headlamp will work with the inner shift knob Processing instructions

## Electronic Humidity Drying Cabinet Operating

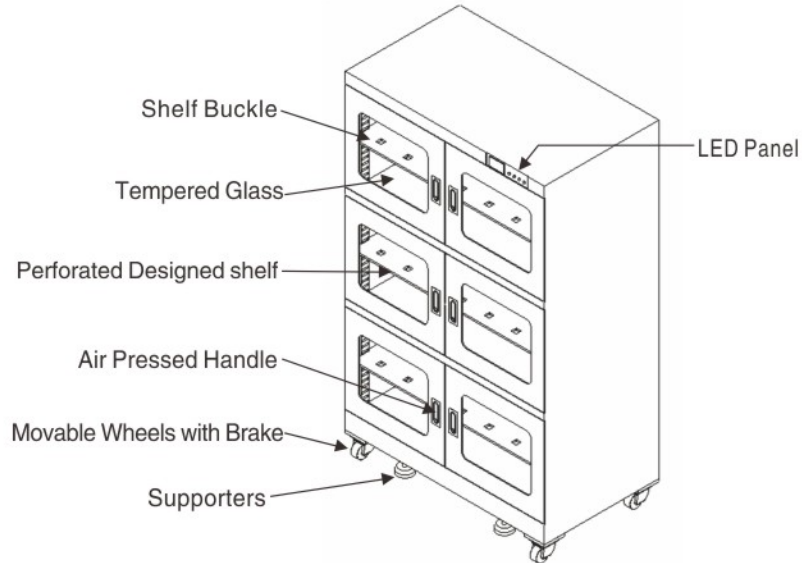

## Using Tips

1. Place this machine in a firm surface and keep the distance from the wall around 20cm for good condition. Press these two braked wheels for fixing then remove bottom feet to the ground.
2. If there are two core components link them first then link the power(110V/50HZ).
3. Humidity setting.  
Screen will show two sets of figures after booting: the green digital displayed on the left shows current humidity which is adjustable; The red digital display on the right shows current temperature which is not adjustable. PLS press "▲" and "▼" two buttons to change humidity. The RH will up or down 1% RH per press. Once loose the button the green digital will show current humidity.
4. First time to be used or reused after a long, PLS run the unit ahead of time at least 12 hrs without any containers to make sure a good condition. Containers to make sure a good condition.
5. The lowest RH values in original, press the "▲" button to increase the values.

6. Setting RH values is lower at least 2%RH than the needed values for the opening influence.
7. The original RH value is at 1%-10%RH ranges, the lowest value, link power and use it directly.

we have applied patent in China, NO.ZL 2012 2 000 1833.6 no imitating

## Normal Single Flow Nitrogen Control Cabinets Processing

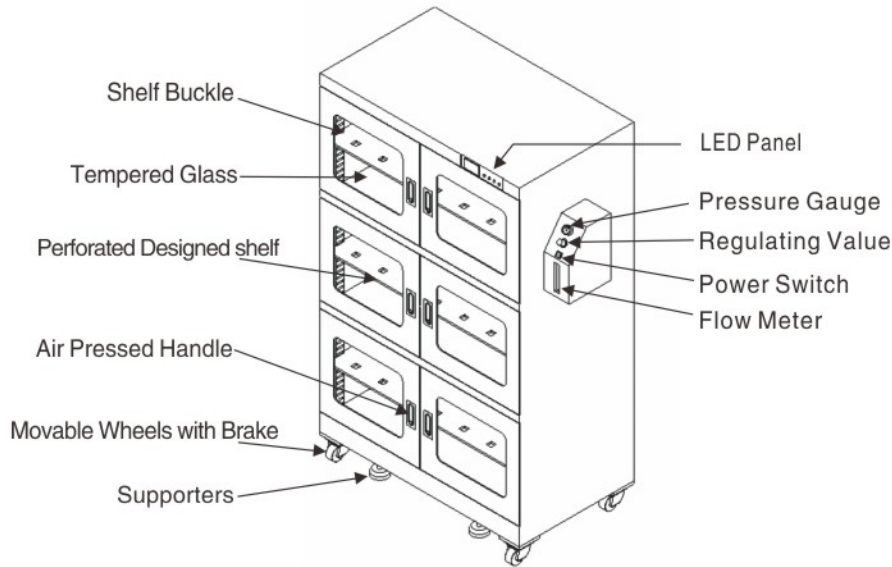

## Using Tips

1. Place this machine to a firm surface, press braked wheels for fixing then remove bottom feet to the ground.
2. Link the power (110V/50HZ) and nitrogen gas inlet.
3. Open the power switch on the nitrogen control box, adjust the gas pressure to 0.2MPa around.
4. Adjust the display to the needed RH values.  
Screen will show two sets of figures after booting. There are two sets of figures: the green digital displayed on the left shows current humidity which is adjustable; The red digital displayed on the right shows current temperature which is not adjustable. PLS press "▲" and "▼" two buttons to change RH value. The RH will up or down 1% per press. Once loose the button the green digital will show current humidity.
5. Make sure the gas flowmeter is at 15L/min  
The inner RH value higher around 5%RH than the needed RH, machine work automatically, input nitrogen until to the set value, the impeller rotor in flow meter will fall to the bottom.

Specific processing tips: Adjust impeller rotor to 15L/min the right scale user(L/min), left scale line for overseas(CFM/hr unit).

6. PLS use pure & clean gas, dirty, impure, moist gas may affect the results and also damage to the nitrogen control system

7. The above tips are useful for drying equipment

Remarks: exchange formula  $0.1\text{MPa} = 1.02\text{Kg/cm}^2 = 14.5\text{Psi}$

$1\text{Psi} = 0.07\text{Kg/cm}^2$

## Double Flow Power Saving Nitrogen Control Cabinets Processing

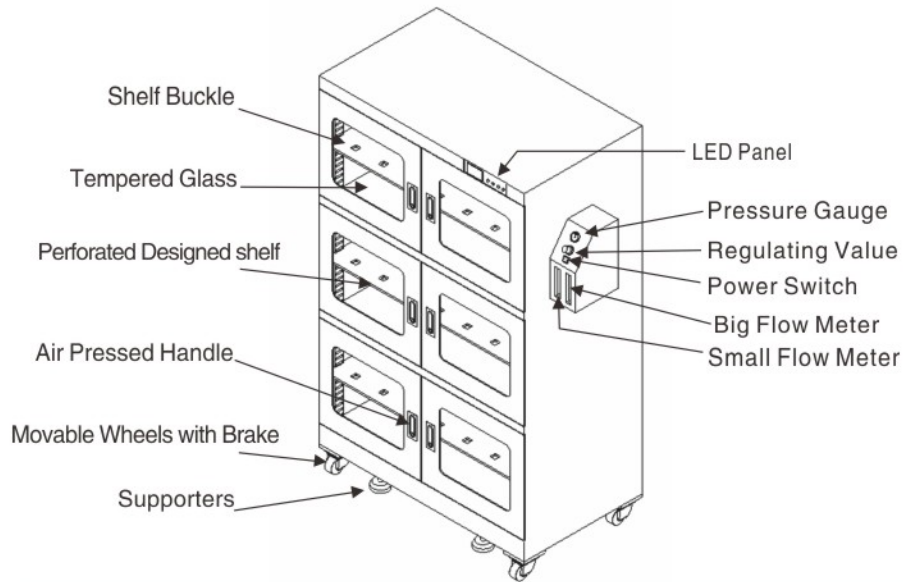

## Using Tips

1. Place this machine to a firm surface, press these two braked wheels for fixing then remove bottom feet to the ground.
2. Link the power (110V/50HZ) and nitrogen gas inlet.
3. Open the power switch on the nitrogen control box, adjust the gas gauge to 0.2MPa.
4. Adjust the display to the needed RH values.

Screen will show two sets of figures after booting: the green digital displayed on the left shows current humidity which is adjustable; The red digital displayed on the right shows current temperature which is not adjustable. PLS press "▲" and "▼" two buttons to change humidity. The RH will up or down 1 %RH per press. Once loose the button the green digital will show current humidity.

5. Tips to adjust the gas flow input

There are two Nitrogen controllers, on the right for wide-range (the best 20-40L/min depends), on the left for small-range ( Min range 0.3L/min ) The inner RH value higher around 5%RH than the sets,

wide-range work automatically and decrease the RH value quickly until to the set value, then the small-range work instead, compare to the traditional, more efficient, power and nitrogen saving at least shorten 50% nitrogen gas consumption.

Specific processing tips: Adjust impeller rotor, the bottom indicate the inner current gas flow, the right scale line for home user (L/min), the left scale line for overseas (CFM/hr unit). Set RH value higher than 15%RH, turn off the small-range for saving time efficiently.

6. PLS use the pure and clean gas, dirty, impure, moist gas may affect the results and also damage to the nitrogen control system.
7. The above tips are useful for drying equipment.

Remarks: exchange formula  $0.1\text{MPa} = 1.02\text{Kg/cm}^2 = 14.5\text{Psi}$

$1\text{Psi} = 0.07\text{ Kg/cm}^2$

We have applied a patent, NO. ZL2013 2 0660291.8 no imitating

## Auto-nitrogen and Humidity Control Cabinets Operation Instructions

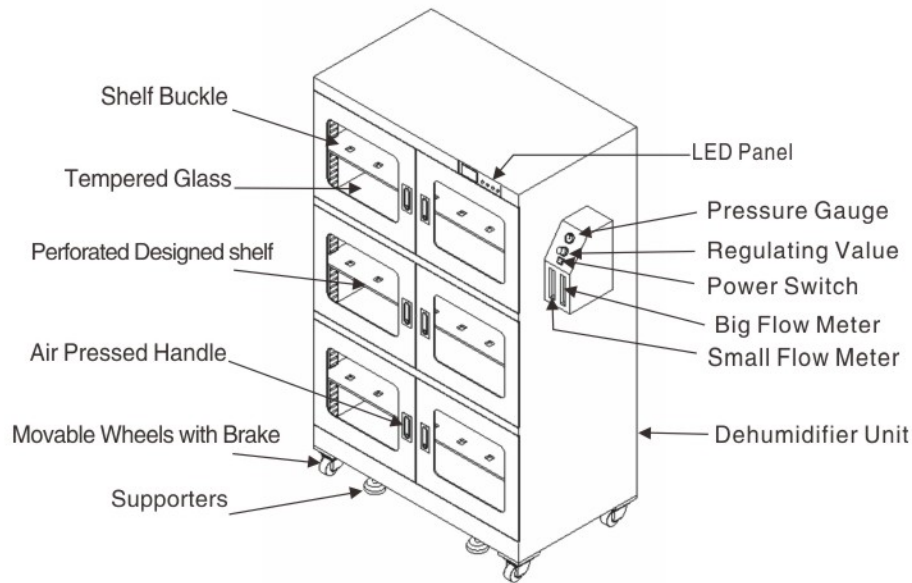

## Using Tips

1. Place this machine to a firm surface. The distance between the machine and the wall should be around 20cm for good condition. Press these braked wheels for fixing then remove bottom feet to the ground.
2. Link the Nitrogen controller on the right and cascade every dehumidify core.
3. Open the power switch on the nitrogen control box, adjust the gas gauge to 0.2MPa.
4. Adjust the display to the ideal RH values.

Screen will show two sets of figures after booting: the green digital displayed on the left shows current humidity which is adjustable; The red digital displayed on the right shows current temperature which is not adjusted. PLS press "▲" and "▼" two buttons to change humidity. The RH will up or down 1%RH per press. Once loose the button the green digital will show current humidity.

5. Make sure the gas flow is at 15L/min for Normal Single flow nitrogen control.

The inner RH value higher around 5 than the setting, machine work automatically, input nitrogen until to the set value, the impellerrotor in flow meter fall to the bottom.

6. Tips to adjust gas flow for double flow power saving nitrogen Controller.

There are two Nitrogen controllers, on the right for wide-range(the best 20-40L/min depends), on the left for small -range(Min range 0.3L/min)The inner RH value higher around 5 than the sets, wide-range work automatically and decrease the RH value quickly until to the set value, then the small -range work instead, compare to the traditional, more efficient, power and nitrogen saving at least shorten 50% nitrogen. Set RH value higher than 15%RH, turn off the small -range for saving time efficiently.

7. Tips to adjust flowmeter: Adjust impellerrotor, the bottom indicate the inner current gas flow, the right scale line for home user(L/min), the left scale line for overseas (CFM/hr unit).

8. After obey these tips above, dehumidifier and the nitrogen will work automatically. The inner RH value higher around 5 than the sets, machine work automatically, input nitrogen until to the set value Dehumidifier will work for the RH value you set.

9. PLS use the pure and clean gas, dirty, impure, moist gas may affect the results and also damage to the nitrogen control system.

10. The above tips are useful for drying equipment.

11. This machine stable inner RH value, nitrogen saving overhand for the Purchasing nitrogen users, use both of them, or tun off another by yourselves just power off the needful box.

we have two nitrogen control systems for options.

Remarks: exchange formula  $0.1\text{MPa} = 1.02\text{Kg/cm}^2 = 14.5\text{Psi}$

$1\text{Psi} = 0.07\text{ Kg/cm}^2$

we have applied patent in China, NO.ZL 2013 2 0660291.8

no imitating&ZL 2012 2 000 1833.6 no imitating

## Automatic Drying Cabinet with N2 Generator

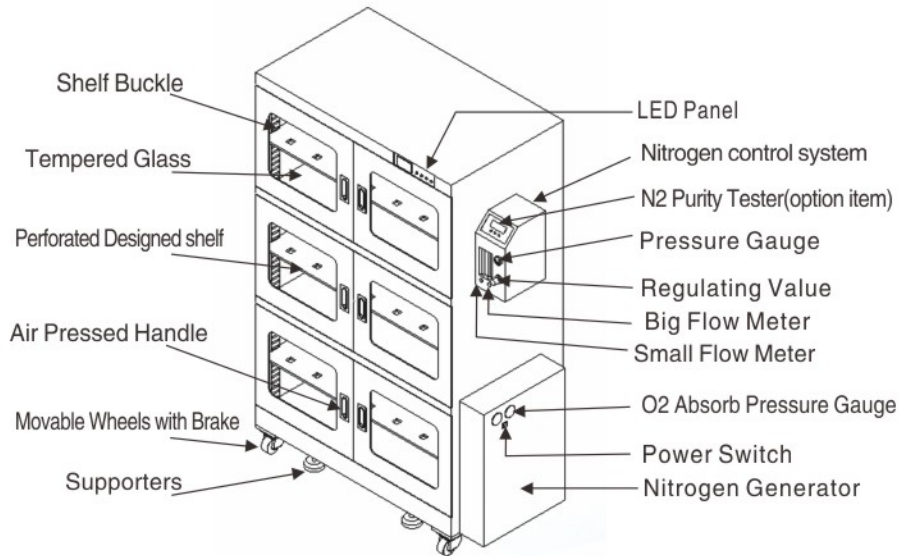

## Using Tips

### I . Principle of PSA System

Equipped with PSA system a new technology nitrogen generator, imported Japanese coke O2 absorb with highly efficient separation can get 99% high purity N2 from the air under the normal condition. As O2 & N2 they are of different rate of diffusion in the coke.

### II . Characters of PSA

Comparing to traditional N2 generator advantages as follows:

- Energy saving using the air as the raw material with high efficiency can produce N2 after operating half an hour.
- Easier operating simpler technology processing just press the button on or off.
- Automatic control system without any supervision.

### III 、 Nitrogen gas making process with PSA system

The air should be filtered through oil & water free compressor with pressure 0.7-0.8MPa, After this process 5N air was formed.

Adjust the pressure vales to 0.6-0.7Mpa on the nitrogen generator, after double filtration a high pure nitrogen gas was formed to the inner cabinet.

To the best condition inner air pressure should be 0.7-0.8Mpa, O2 Absorb Pressure Gauge should be above 0.6Mpa

### IV 、 Cautions

1. PLS read the instructions carefully before operating otherwise it may cause damage.
2. The air should be filtered through oil & water free compressor. PLS don't forget to discharge oil and water at regular intervals.
3. Both the two vales on the nitrogen generator are above 0.6Mpa.
4. In order to make sure the good effect, the coke should be replaced at a fixed period, normally 3-5years.
5. Make sure the compressor opened & cut off the gas supply valve collect to the compressor otherwise may cause dangerous.

### V 、 Warning

This machine can produce high pure nitrogen gas which is dangerous to our life so PLS using it under ventilation.

### VI 、 Operation Instructions

1. Place this machine to a firm surface. Fixed the brake on wheels then remove bottom feet to the ground for fixing.
2. Link the power (220V/50HZ) and 8mm nitrogen gas inlet on the back of N2 generator, make sure the inner gas pressure should be 0.7-0.8Mpa, at least 0.7Mpa under the condition of oil & water free compressor.
3. Open the power switch on the nitrogen control box, adjust the gas pressure to 0.2MPa around.

Remarks: exchange formula  $0.1\text{MPa} = 1.02\text{Kg/cm}^2 = 14.5\text{Psi}$

$1\text{Psi} = 0.07\text{Kg/cm}^2$

we have applied patent in China, NO.ZL 2013 2 0660291.8 no imitating



## FAQ & Solutions

PLS check the following tips before applying for the after sales service (used for humidity Control and nitrogen Controlseries)

Unusual phenomenon	Possible reasons & solutions
Display doesn't work	The machine is linked correctly and well
	Fuse burn-out for the Overload current PLS change the fuse as the following picture
	Cascade every dehumidifier machine core
Unchangeable display	system halted, turn off the power or re-link
	Make sure the humidity sensor and display contact closely
The RH values decrease slowly	No air flow such as conditioner
	Put too much items, excessive moisture content of themselves so as it will take more time to the set RH vales
	Press buttons to adjust the RH values
	Send dehumidifier core or nitrogen controller to us for repairing

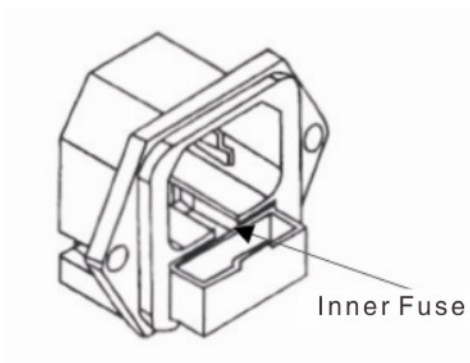

Diagram of Replacing Fuse

### Special tips:

1. Machine broken contact with us first time we will guide for your repairing
2. Do not open this machine in private without our permission otherwise there won't any guarantee.

## Applications and Reference Humidity for Storing Items

Condition(RH range)	Recommended RH value for various article storage
50%RH-40%RH	Magnetic tape, disk, VCD, camera, camera, lens, projector, Telescope, photographs, musical instrument, microscope, film, slides, Digital camera, tape, ancient calligraphy and painting, water color painting, oil painting, stamps, Coin, antique, CD, LD, photo album, mechanical drawing, advertising design, fur and industrial design etc.
40%RH-20%RH	Precision instruments, electrical and electronic products, measuring tool, precision molds, semiconductor products, capacitor, tungsten wire, battery, optical film and instruments, printed circuit boards, sensors, charger, optical lens etc.
25%RH	Lab medicinal materials, chemical powder, sample, filter, models, seed, pollen, dry flower, tea, coffee, seaweed products, spices, dry food etc.
15%RH	Special chemicals, precision electronic components

### Functions and Features:

1. Powersaving, environmental, silent.

Environmental design, small power, power saving, super-silence.

2. Steady humidity.

the RH value achieve the set value fast and steadily under the condition of room temperature 25 degrees and relative humidity 60% RH.

3. Power reserve dehumidifier function.

The inner RH value we can control within 10% after the power off during 24 hrs, no need to reset after pow off for the automatic memory function.

Detailed information please refer to thereal items finally.

## Product model

Item	Model	Outer Size W*D*H(mm)	Inner Size W*D*H(mm)
GRD-A/B/C/N	160	450*450*1010	405*420*840
GRD-A/B/C/N	240	600*450*1280	555*420*1110
GRD-A/B/C/N	320	900*450*1010	855*570*840
GRD-A/B/C/N	450	900*600*1010	855*570*840
GRD-A/B/C/N	540	600*690*1485	555*640*1315
GRD-A/B/C/N	730	600*690*1830	555*640*1660
GRD-A/B/C/N	880	900*600*1860	855*550*1680
GRD-A/B/C/N	1430-4	1200*690*1830	1155*640*1660
GRD-A/B/C/N	1430-6	1200*690*1830	1155*640*1660

- \* A indicates humidity control range 20%-60%RH(Delet).
- \* B indicates humidity control range 10%-20%RH.
- \* C indicates humidity control range 1%-10%RH.
- \* N nitrogen control drying cabinet with humidity control range 1%-60%RH.
- \* F indicates antistatic fuction (optional accessory).